



18 GHz SMA LATCHING S.P.7 T. SWITCH

OPTIONS : /SELF CUT-OFF /AUTO RESET / TTL DRIVE /SUPP.DIODES

R F CHARACTERISTICS

NUMBER OF WAYS : 7
 FREQUENCY RANGE : 0 - 18 GHz
 IMPEDANCE : 50 Ohms

FREQUENCY (GHz)	0 - 3	3 - 8	8 -12.4	12.4- 16	16 - 18
V.S.W.R <=	1.20	1.30	1.40	1.50	1.60
INSERT. LOSS <=	0.20 dB	0.30 dB	0.40 dB	0.55 dB	0.60 dB
ISOLATION >=	80 dB	70 dB	60 dB	60 dB	60 dB
AVER. POWER (*)	240 W	150 W	120 W	110 W	100 W

ELECTRICAL CHARACTERISTICS

ACTUATOR : LATCHING
 NOMINAL CURRENT AT 25° C (±10%) : 960 mA
 ACTUATOR VOLTAGE (Vcc) : 12V (10.2 to 13V) / NEGATIVE COMMON
 TERMINALS : solder pins (250 deg.C max./30 sec.)
 SELF CUT-OFF TIME : 40 ms < CT < 120 ms
 TTL INPUTS (E) - High level : 2.2 to 5.5V / 800µA at 5V
 - Low level : 0 to 0.8V / 20µA at 0.8V

MECHANICAL CHARACTERISTICS

CONNECTORS : SMA female per MIL-C 39012
 LIFE : 2.000.000 cycles per position
 SWITCHING TIME (nominal voltage;25° C) : < 50 ms
 CONSTRUCTION : splashproof
 WEIGHT : < 280 g

ENVIRONMENTAL CHARACTERISTICS

OPERATING TEMPERATURE RANGE (°C) : -40 , +85
 STORAGE TEMPERATURE RANGE (°C) : -55 , +85

(* : average power at 25° C per RF path)

This information is given as an indication. In the continual goal to improve our products, we reserve the right to make any modifications judged necessary

4112-9212

DRAWING

General tolerance: ± 0,5 mm

R573 482 720

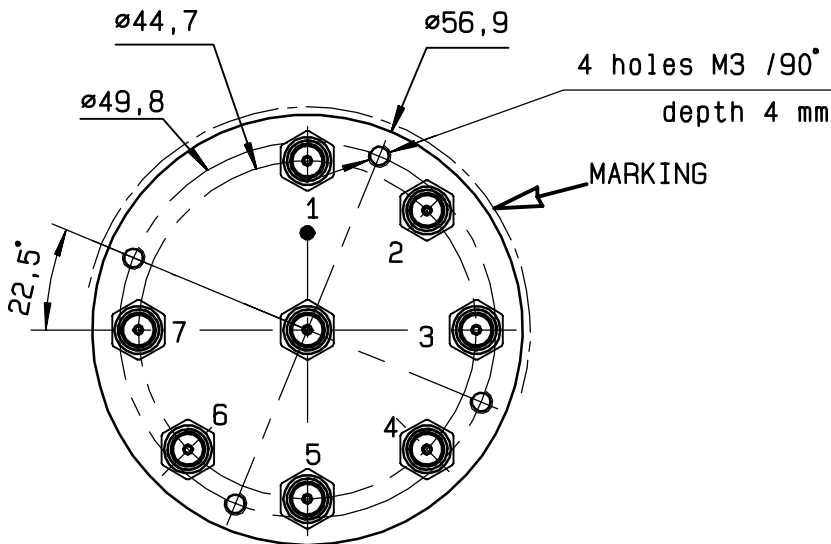

TTL input	RF continuity
E1 = 1	IN ↔ 1
E2 = 1	IN ↔ 2
E3 = 1	IN ↔ 3
E4 = 1	IN ↔ 4
E5 = 1	IN ↔ 5
E6 = 1	IN ↔ 6
E7 = 1	IN ↔ 7

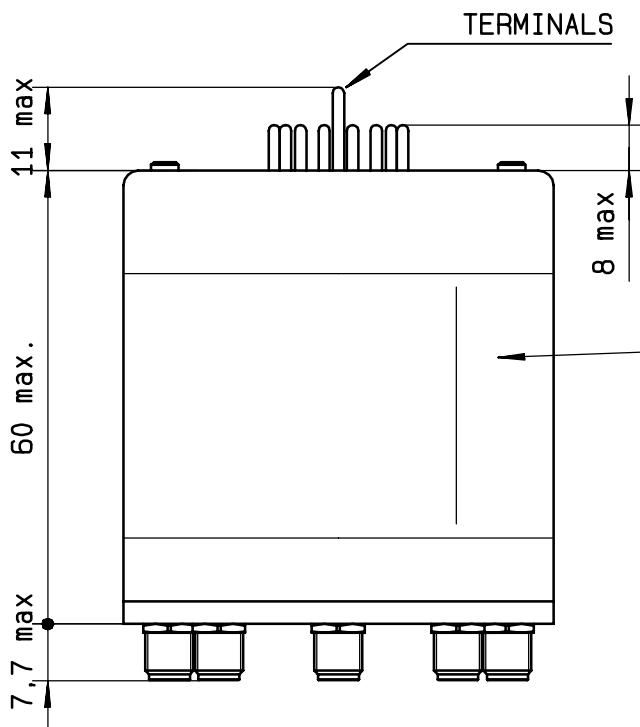

MARKING TOP VIEW (TERMINALS)

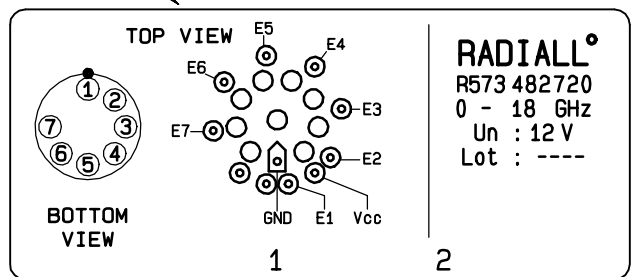

RADIALL^o
 R573 482 720
 0 - 18 GHz
 Un : 12 V
 Lot : ----

SCHEMATIC DIAGRAM

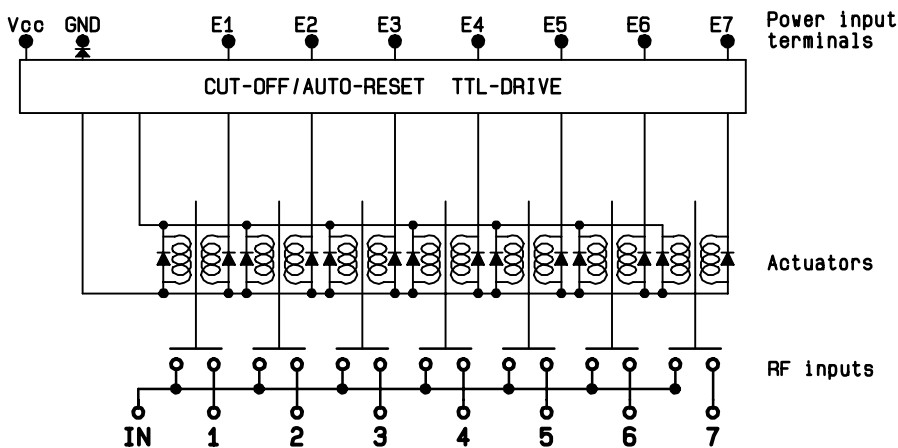

This information is given as an indication. In the continual goal to improve our products, we reserve the right to make any modifications judged necessary

4113-9212